

TR

RULLIERE O TRASPORTATORE A RULLI
ROLLER CONVEYOR / TABLES À ROULEAUX

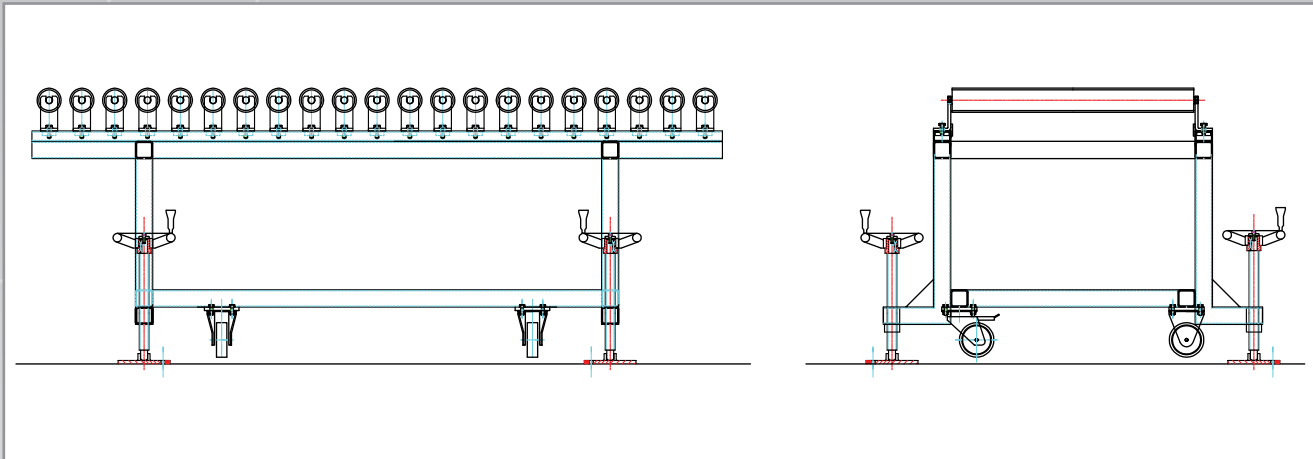

CT/D

TRASPORTATORE A COCLEA
SCREW CONVEYOR / TRANSPORTEUR À VIS SANS FIN

TRASPORTATORE A COCLEA serie CT/D - COD.F-06-07
 SCREW CONVEYOR CT/D SERIES / TRANSPORTEUR À VIS SANS FIN SÉRIE CT/D

Cod.	Tipo	Diametro esterno coclea	N° giri/min orientamento °	Portata media m³/h	Potenza installata kw	Peso testate kg	Peso medio kg/m
	Type	Screw external diameter	Rpm orientation °	Average payload m³/h	Installed power kw	Heads weight kg	Mean weight kg/m
	Type	Diamètre vis sans fin	Tour/min orientation °	Portée moyenne m³/h	Puissance installée kw	Poids têtes kg	Poids moyen kg/m
F-06-07-02-00	CT/D 150	150	60 / 0°	3	0,75 / 4	80	25
F-06-07-04-00	CT/D 200	200	60 / 0°	5	1,5 / 7,5	120	32
F-06-07-06-00	CT/D 250	250	60 / 0°	10	3 / 9,2	150	40
F-06-07-08-00	CT/D 300	300	60 / 0°	15	4 / 11	190	50

